

NC-125-V12LH_440規格說明	
工位數	12
中心高(mm)	125
刀盤直徑(mm)	440
內徑刀柄徑(mm)	Ø40
外徑刀柄寬(mm)	□25
端面刀柄寬(mm)	□25
工作壓力(kg/cm <sup>2</sup> )	40
離合器夾緊力(kg)	6000
高壓出水(bar)	70
伺服傳動速比	1:60
定位精度(Deg)	"± 2"
重複定位精度(Deg)	"± 1"

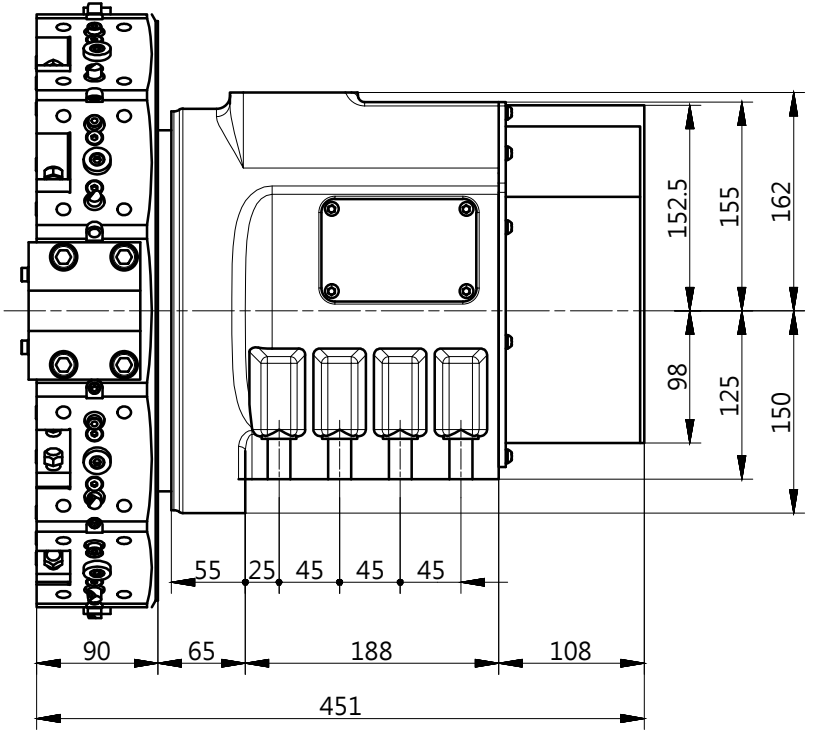
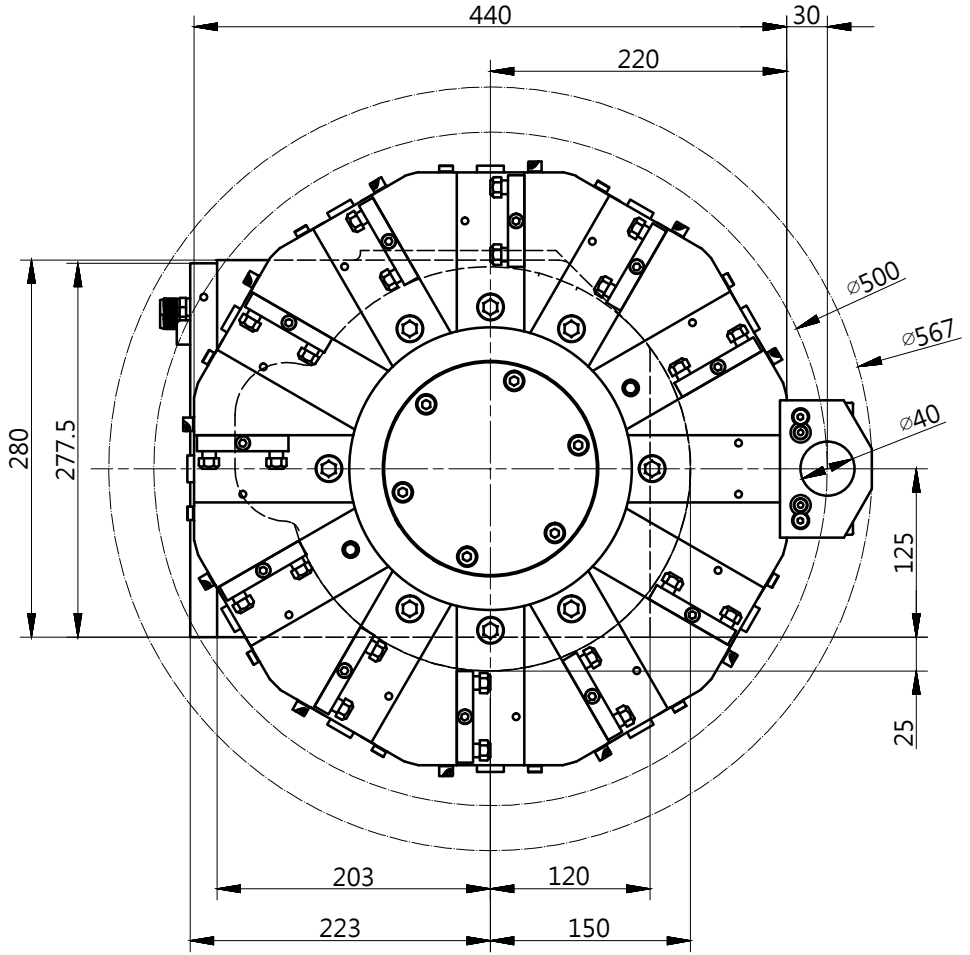
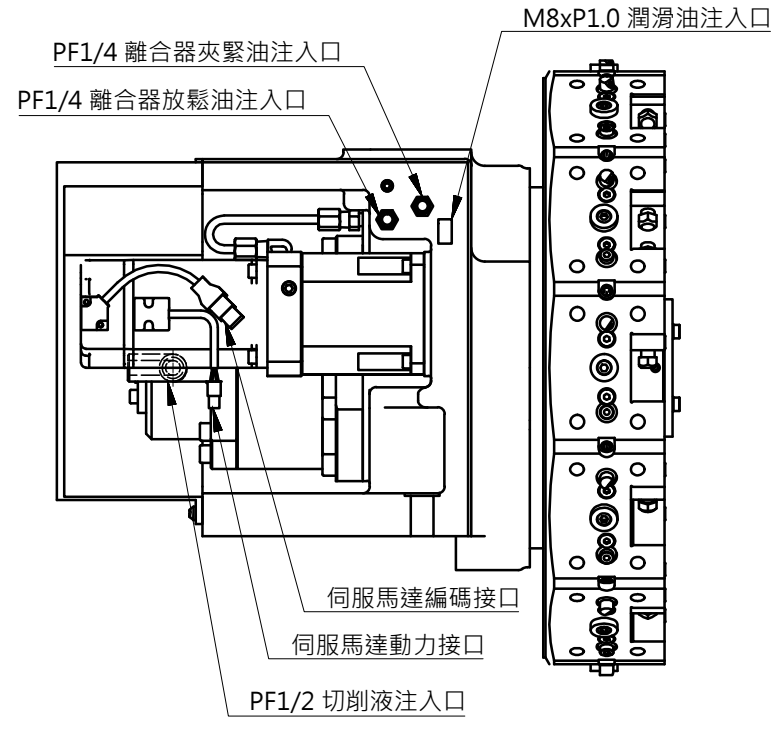
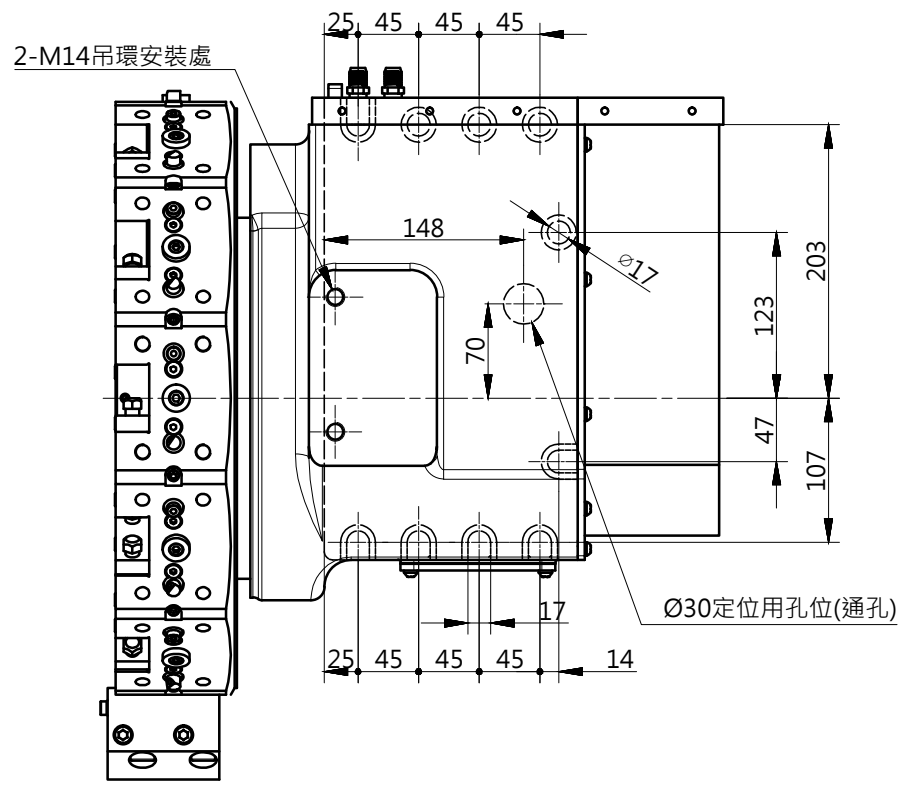
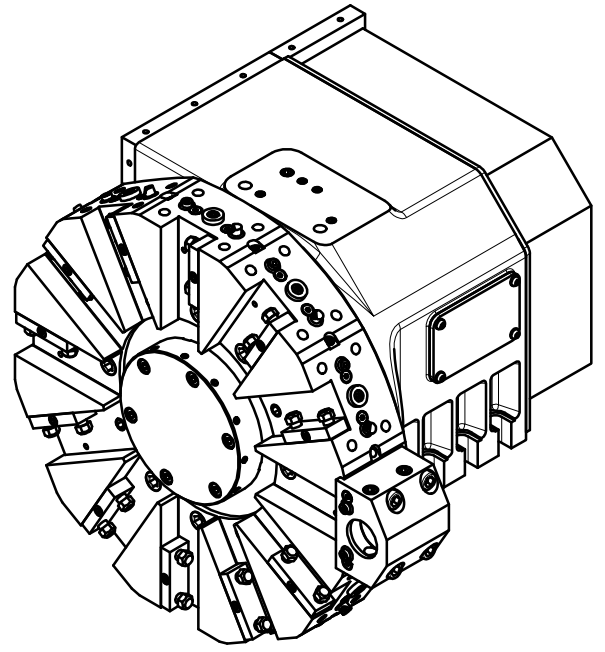
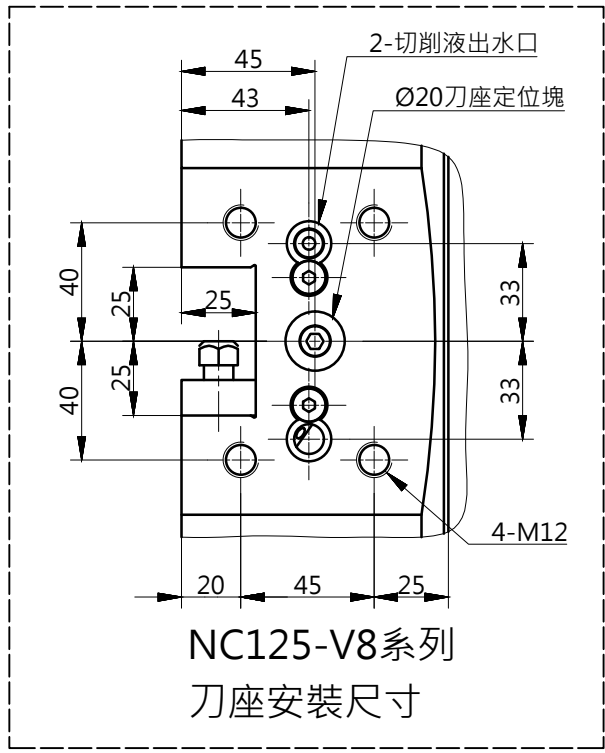

品名 NC125伺服刀塔V12LH_440型	圖號 NC-125-V12LH_440		
 鉦通工業股份有限公司 <small>Jhen Tong Precision Co., LTD.</small>	繪圖 李秉倫	校對	核准
	日期	2017/4/11	